

**LUMEL**

**ELECTRONIC  
TEMPERATURE  
CONTROLLER  
RE53**

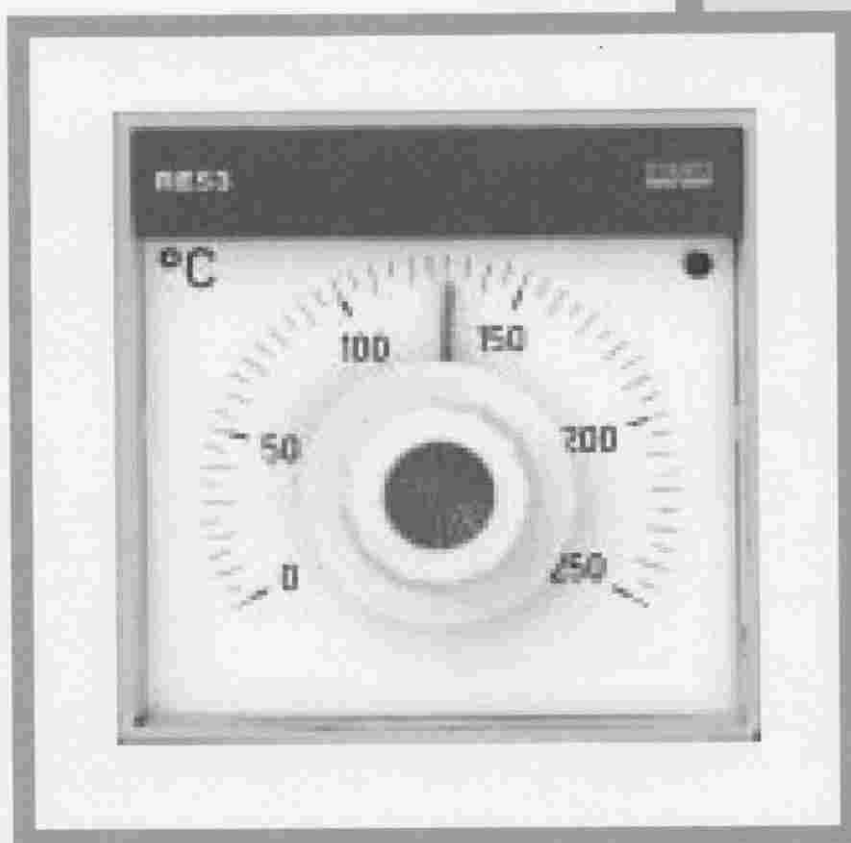

**USER'S MANUAL**

**CE**

# CONTENTS

Page

1. APPLICATION .....	3
2. CONTROLLER SET .....	3
3. BASIC REQUIREMENTS AND OPERATIONAL SAFETY .....	4
4. DESIGN DESCRIPTION .....	4
5. FITTING .....	6
6. ELECTRICAL SCHEME OF CONNECTIONS .....	8
7. TECHNICAL DATA .....	9
8. EXECUTION CODES .....	11
9. MAINTENANCE AND GUARANTEE .....	12

# 1. APPLICATION

The RE53 electronic controller is destined to be used in automatic control systems and process control systems as a temperature controller or controller of other physical quantities converted into a standard current or voltage signal.

A simple operational algorithm and easy-to-use controller servicing make that it find a large application in signalling and temperature control systems in industrial furnaces,

drying ovens, plastics processing machines, and other devices.

The servicing is very simple and one does not require special knowledge in the field of automation for the servicing of these controllers.

# 2. CONTROLLER SET

With the meter we deliver:

- two holders to fix the meter on a panel,
- a service manual,
- a guarantee certificate.

When unpacking the meter, please check whether the type and execution code on the data plate correspond to the order.

Symbols located in this service manual mean:



Especially important, one must acquaint with this before connecting the meter.



One must take note of this when the meter is working inconsistently to the expectations.

### **3. BASIC REQUIREMENTS, OPERATIONAL SAFETY**



RE53 controllers are destined to be mounted into panels and cubicles.

In the range of operational safety they are in conformity with IEC 1010 -1+A1:1996 standard requirements.

- The installation and meter connection should be operated by qualified personnel.
- One must take into consideration all accessible protection requirements
- Before switching the instrument on, one must check the correctness of the network lead connection - IEC 1010 - 1 p.6.10. and p.6.11.2.
- In case of the protection terminal connection with a separate lead one must remember to connect it before the connection of network leads.
- Do not connect the meter to the network through an autotransformer.
- Before taking the meter housing out one must turn the supply off.
- The removal of the meter housing during the guarantee contract period may cause its cancellation.

### **4. DESIGN DESCRIPTION**

The RE53 controller consists of easy exchangeable sub-assemblies placed in a housing made of thermoplastics materials. Elements of the electronic system, the terminal strip and the setting potentiometer are fixed on a P.C. board .

The view of the controller is shown on the fig.1.

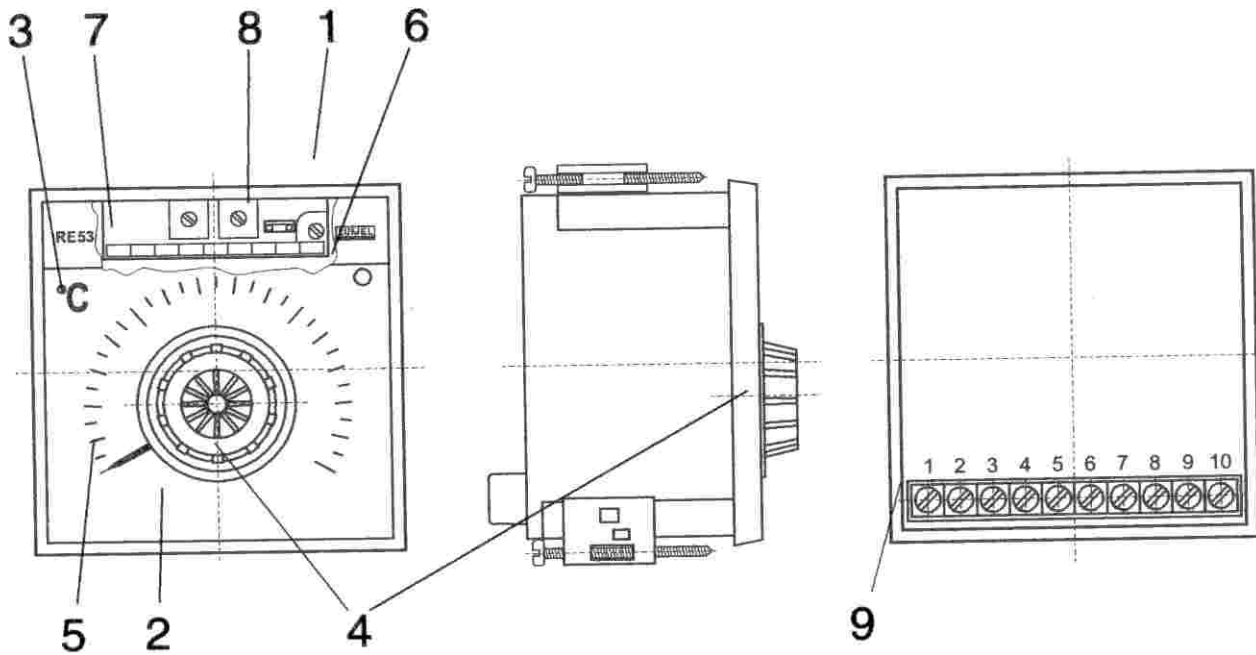

**Fig . 1. RE53 controller - external view.**

- |                             |                          |
|-----------------------------|--------------------------|
| 1. Housing                  | 6. Signalling diode      |
| 2. Glass                    | 7. Diode deviation index |
| 3. Dial-plate with markings | 8. Feedback jumper       |
| 4. Knob                     | 9. Terminal strip        |
| 5. Pointer                  |                          |

From the frontal side, under the glass, there are the dial-plate with markings, the pointer, the deviation index and the signalling diode. A cut-out is made in the upper part of the dial-plate enabling the access to the feedback jumper.

In case of the feedback switching on, the jumper is positioned horizontally.

In case of the feedback switching off, the jumper is positioned vertically.

The change of the jumper position can be carried out when the supply voltage is switched off, using tweezers or flat nose pliers.

A special execution of the knob protects against any accidental settings of the controller set point.

To change the setting of the set point one must insert the forefinger into the middle of the knob, grasp it with the thumb and turn it towards the desired direction.

The lighting of the signalling diode informs us about the short-circuiting of the relay contacts or voltage occurrence on the voltage output of OC type.

Behind the glass, in the upper part of the controller dial-plate, a deviation index built on LED diodes is placed. The lighting of extreme diodes means a deviation greater than + or - 10% of the controller range.

The terminal strip is placed on the rear wall of the housing. When we turn on the screws in the terminal strip, the washers rise, what radically facilitates the connection of electrical leads.

## **5. CONTROLLER FITTING**

To fix the controller in the panel , one must prepare a 92 x 92 mm hole according to the fig.2.

Introduce the controller from the front of the panel when the supply circuit is turned off and fasten it by means of holders, which are delivered together with the controller.

Sensor leads, supply and load leads must be connected according to the fig.3. All connections must be made with accuracy after cleaning the lead ends.

Leads connecting the controller with thermocouples should be in accordance with IEC standards.

Resistance thermometers should be connected through a three-wire line.

All lines must be made of similar leads.

In order to minimize the influence of interferences , the signalling leads must be conducted separately from the supply leads and load leads and it is recommended to supply the controller from another phase than the load circuit.

**Note:**

The RC system, extinguishing all overvoltages occurring when disconnecting the load circuit, is connected in parallel to the relay contacts.

When contacts are open during the load, a residual voltage appears resulting from the flowing current through the extinguishing system (ca 0.32 mA, at 220 V a.c. ).

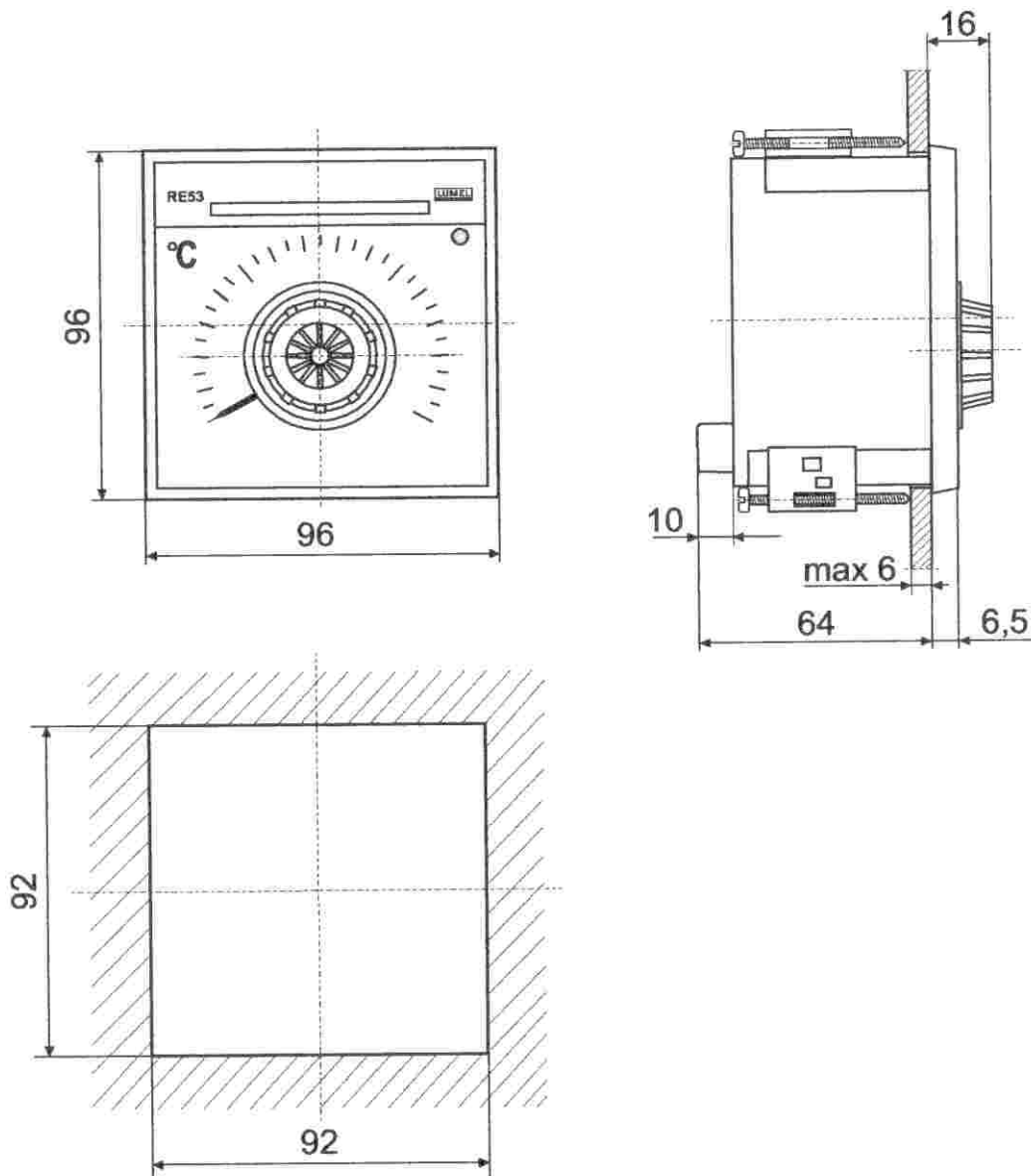

**Fig.2. Overall controller dimensions and panel cut-out dimensions**

## 6. ELECTRICAL SCHEME OF CONNECTIONS

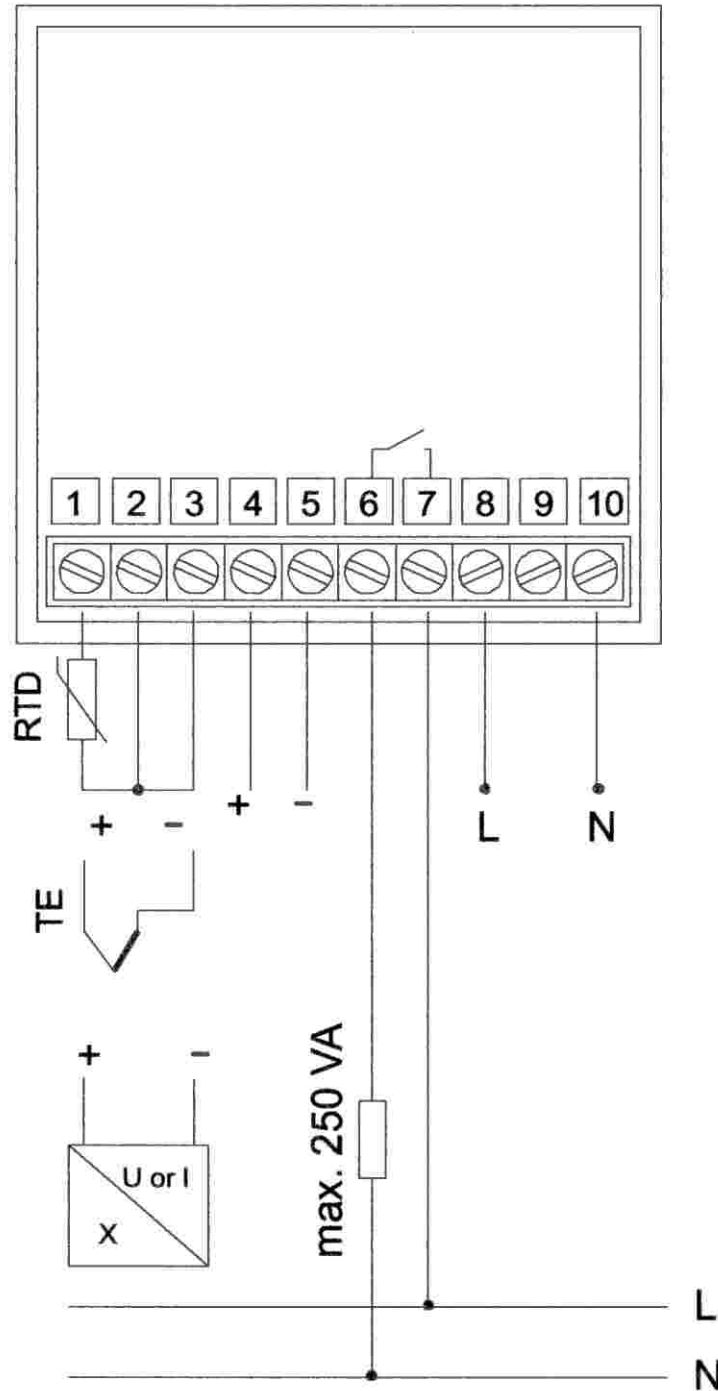

**Fig.3. Electrical connections**

## 7. TECHNICAL DATA

Execution codes and the coding way are given in the table 2.

**Basic error** 1%

**Hysteresis zone** 0.7%

### Input:

- thermocouples PtRh10-Pt, Fe-CuNi, NiCr-NiAl,
- resistance thermometers Pt100/1.3850, Ni100,
- potentiometric transmitter 100  $\Omega$  and 1000  $\Omega$

*Resistance of connecting leads:*

- $R \leq 5 \Omega$  for each lead and controllers with a resistance input,
- $R \leq 10 \Omega$  for each lead and controllers with a voltage input.

### Operation algorithm:

- two-state with hysteresis
- two-state with a correcting feedback of PD type  
proportional range: 3...5%  
switching frequency: 2...5 cycles/minute

**Output:** make contacts of the RM96Z relay

$$I_{\max} = 1 \text{ A}, U_{\max} = 250 \text{ V a.c.}$$

$$S_{\max} = 250 \text{ VA}$$

OC output voltage

$$U_{\text{output}} = 12 \text{ V}, R_{\text{load}} \geq 1 \text{ k}\Omega$$

### Rated operation conditions:

- supply voltage 230 V a.c. (-15%+10%), 48...65 Hz,  
115 V a.c. (-15%+10%), 48...65 Hz
- ambient temperature 0...20...50°C
- relative humidity 25...85%

**Power consumption**  $\leq 3.3 \text{ VA}$

### Protection degree ensured by the housing:

- from the frontal side IP40
- from the terminal side IP20

**Overall dimensions:** 96 x 96 x 64 mm

**Panel cut-out:** 92 x 92 mm

**Weight of the controller** 325 g

**Control ranges of the RE53 controller****Table 1**

<b>Input</b>	<b>Range</b>	<b>Code</b>
Pt100/1,3850	-50...100°C	<b>01</b>
	0...100°C	<b>02</b>
	0...150°C	<b>03</b>
	0...250°C	<b>04</b>
	0...400°C	<b>05</b>
	0...600°C	<b>06</b>
Fe-CuNi	0...250°C	<b>07</b>
	0...400°C	<b>08</b>
	0...600°C	<b>09</b>
	0...900°C	<b>10</b>
NiCr-NiAl	0...600°C	<b>11</b>
	0...900°C	<b>12</b>
	0...1300°C	<b>13</b>
PtRh10-Pt	0...1600°C	<b>14</b>
Voltage or current	0...5 V	<b>15</b>
	0...10 V	<b>16</b>
	0...20 mA	<b>17</b>
	4...20 mA	<b>18</b>
Potentiometric transmitter	0...100 Ω	<b>19</b>
	0...1000 Ω	<b>20</b>
Ni100/1,617	- 50...0°C	<b>21</b>
	- 30...20°C	<b>22</b>
	0...50°C	<b>23</b>
	0...100°C	<b>24</b>
	0...150°C	<b>25</b>
<i>On order (after agreeing with the producer)</i>		<b>99</b>

## 8. EXECUTION CODES

Execution codes of the RE53 controllers

Table 2

RE53 temperature controller	xx	x	x	x	x	xx	x
<b>Input:</b> write the range code from table1	xx						
<b>Operation algorithm:</b> two-state with hysteresis two-state with PD feedback		0 1					
<b>Indicator of control error:</b> controller without indicator controller with indicator			0 1				
<b>Output:</b> relay output transistor output, OC type, 12 V d.c.				0 1			
<b>Supply voltage:</b> 230 V 50/60 Hz 115 V 50/60 Hz 24 V d.c.					0 1 2		
<b>Kind of execution:</b> standard execution custom-made execution						00 99	
<b>Additional requirements:</b> without additional requirements with a quality inspection certificate according to the customer's agreements *							0 1 X

\* the execution code will be settled by the producer

### **Order example:**

RE53 07-1-1-0-2-00-1 means: A RE53 controller, input: Fe-CuNi for the range:0...250°C, two-state operation algorithm with PD feedback, with an error indicator, relay output, supply voltage: 24 V d.c., standard execution, with a quality inspection certificate.

In case of a custom-made execution or need of more detailed technical information please contact our Export Department.

## **9. MAINTENANCE AND GUARANTEE**

The RE53 controller does not require any periodical maintenance. In case of some incorrect controller operations or failures one must contact the nearest authorized workshop.

### **1. In the period of 12 months from the date of purchase:**

One should take the controller down the installation and return it to the LUMEL's Claim Section in the Quality Control Department. If the unit has been used in accordance with the instructions, LUMEL S.A. guarantees to repair it free of charge.

### **2. After the guarantee period:**

One should turn over the controller to repair it in a certified service workshop. The disassembling of the housing causes the cancellation of the granted guarantee.

Spare parts are available for the period of ten years from the date of purchase .

**LUMEL S.A. reserves the right to make changes in design and specifications of any products as engineering advances or necessity requires.**